



Tru-Comfort System

**Cooling Seat Cushion
User Manual**

www.viotek.com



For more information, please visit
www.viotek.com or email a request to:
support@viotek.com

Customer Service: 1-855-229-9472

Table of Contents

Safety Warnings	4
Cleaning & Storage	4
Box Contents	5
Installation	6
In Car	6
In Home/Office	7
How to Use the Remote	8
Troubleshooting	9
Disposal at End-of-Life	10
Specifications	10
One Year Limited Hardware Warranty	11

Safety Warnings

- Properly dispose of all packaging material. Some items may be packed in plastic bags or material and may cause suffocation or injury to pets or children.
- Verify that all parts of the product are accounted for. If any part is missing, contact customer service.
- If any ports or cables or surrounding parts are damaged, do not use the product.
- Never insert objects into the product other than the cables etc. as described in this manual.
- The product is not a toy. Do not leave children unsupervised around the product.
- Use only the parts included in the original packaging or received from the manufacturer.
- Expected use is for standard size seats indoors and in cars only.
- Never submerge the product or any of the product's components and/or accessories.
- The product shall only be used as described in this manual.

Cleaning & Storage

- Risk of shock. Do not allow water and/or liquids to come in contact with any part of the product.
- Use dry, non-abrasive cloth to gently remove debris or dust. Do not spray liquids onto the product.
- Cover the product to protect it from dust. Do not store in a dusty environment as, with all electronic devices, this may cause damage over time.

Box Contents

Cooling Seat Cushion

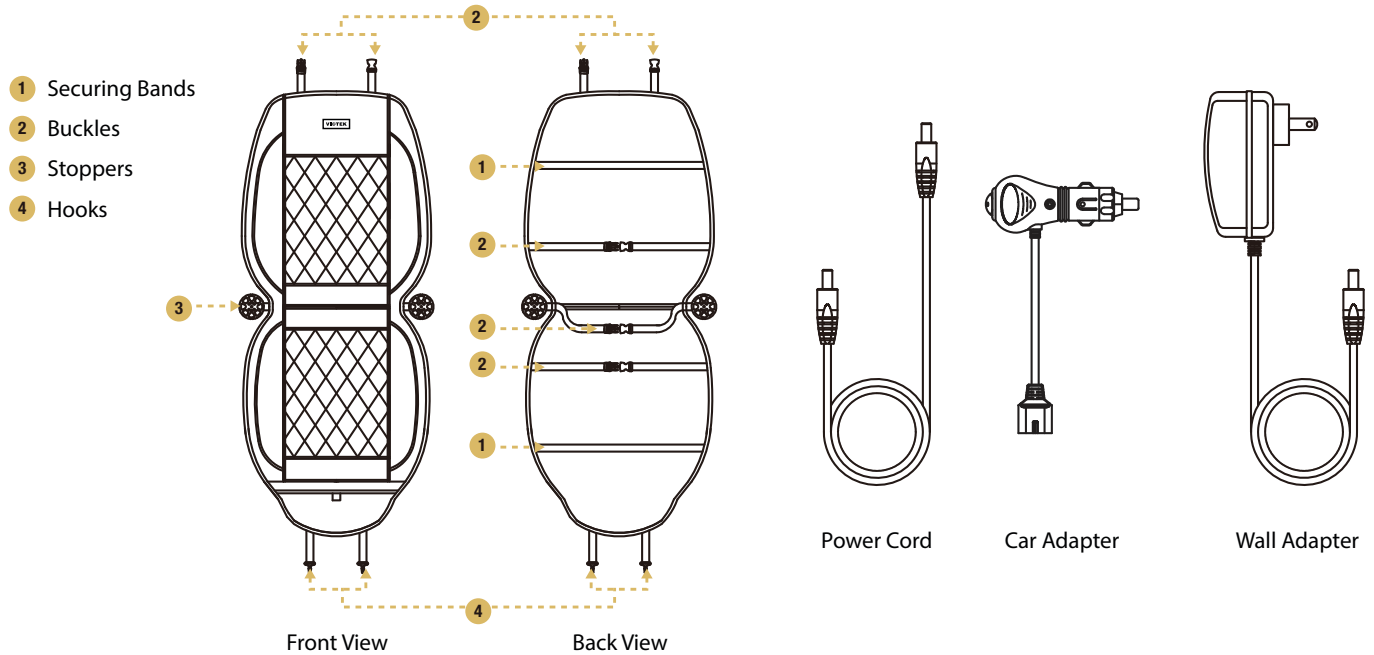

Note: If needed, the fuse within the Car Adapter may be replaced. Replacement fuse is included.

Installation

In Car

1. Slip the Securing Band over the head rest and down the back of the seat.
2. Fasten the Buckle around the back of the seat and the headrest.
3. Carefully push the Stoppers through the gap between the seat sections. Use the Stoppers to secure the cushion's position.
4. Pull the front of the cushion around the edge of the seat and under the bottom the seat. Use the metal hooks to secure it to the undercarriage of the seat.
5. Connect the Power Cord to the seat cushion and the Car Adapter. Then, insert the adapter into a cigarette lighter receptacle.

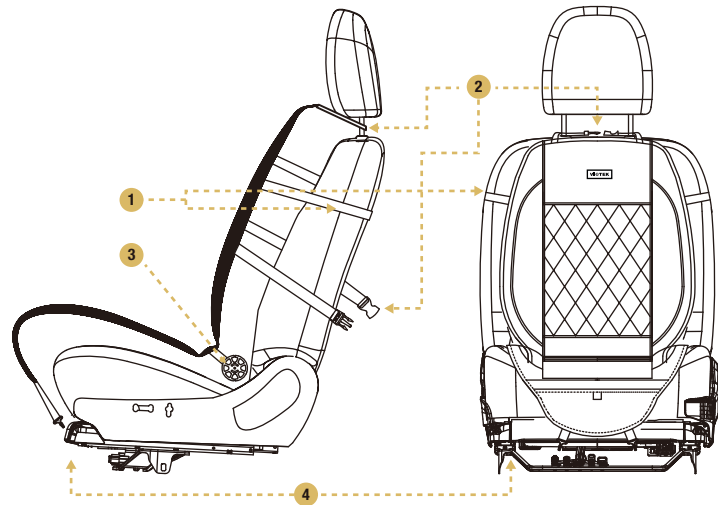

In Home/Office

Note: Some steps may be skipped or require modification according to the type of seating used.

1. Slip the first Securing Band and over the headrest and down the back of the seat. Next, slip the remaining band across the bottom of the seat.
2. Fasten the three buckles around the back and the bottom of the seat.
3. Use the Stoppers to secure the cushion's position as needed.
4. Pull the front of the cushion around the edge of the seat and under the bottom the seat. Use the metal hooks to secure it to the undercarriage of the seat as needed.
5. Connect the Wall Adapter to a suitable outlet or use a powerbank.

Note: Powerbank not included.

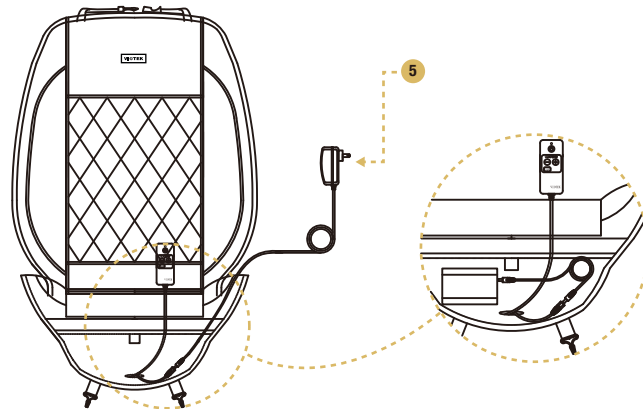
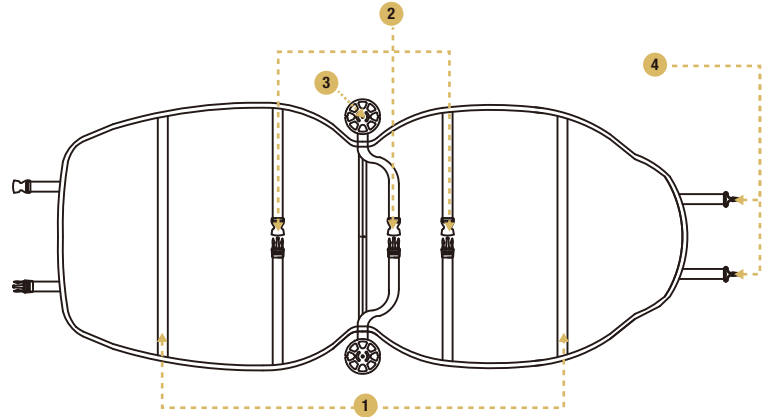

How to Use the Remote

For convenience, the remote is attached to the cushion. Note, the cushion starts at cooling level 3 by default and features a total of 5 levels with 5 being the coolest.

1. Press the power button to turn the cushion on. The indicator light will turn on to indicate the cushion is on.
2. Press (+) to increase the cooling level or (-) to decrease the cooling level. Press either button to adjust to the desired level.
3. Press the power button to turn the cushion off. When off, the blue light will turn off to indicate the cushion is off.

WARNING: Do not operate the remote while driving.

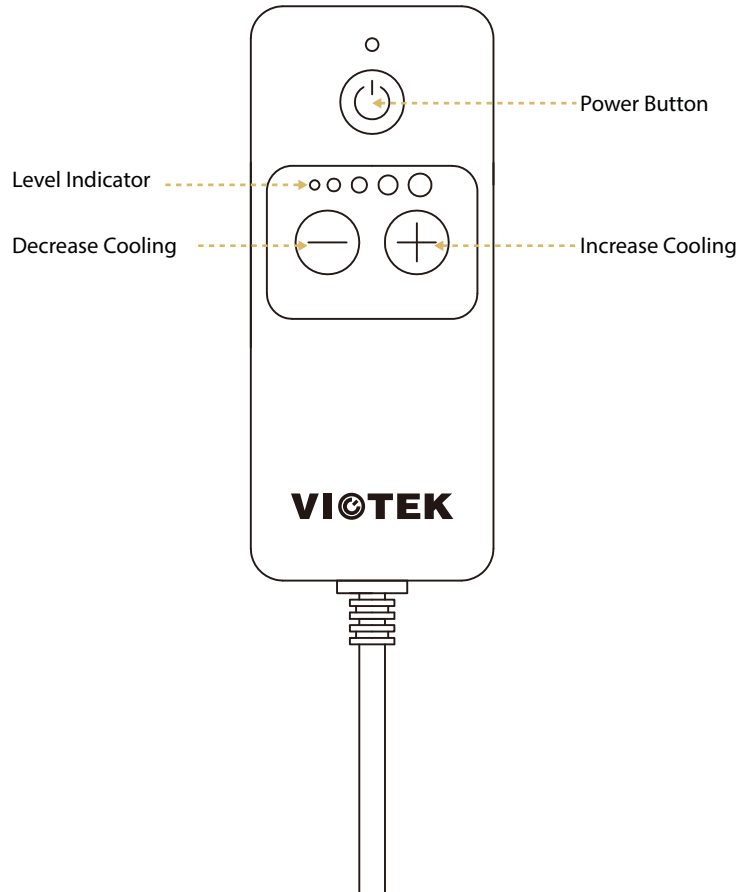

Troubleshooting

1. The cushion does not turn on.

- Check if all cables are properly connected.
- Check if the Car Adapter is properly inserted into the cigarette lighter receptacle.

2. The cushion moves and/or shifts.

- Check if the cushion is positioned in the center of the seat.
- Check if both the Securing Band(s) and Buckle(s) are fully secure.

3. The cushion does not work.

- Try pressing the remote button again.
- Check if all cables are properly connected.

Note: If none of the above information resolves your issue, please visit our website at www.viotek.com or contact customer service at 855-229-9472.

Disposal at End-of-Life

If disposing of this product, it is considered electronic waste and should not be mixed with household trash. The recommended disposal for any VIOTEK® Cooling Seat Cushion at its end-of-life is to dispose of the entire unit at or through an e-waste recycling center, program, or facility. Local regulations and laws pertaining to the recycling and disposal of certain electronic components and plastics and/or products containing them will vary according to country, state, and local governments. You must check laws and regulations corresponding to where you live in order to properly dispose of the battery and/or unit. It is the user's responsibility to dispose of their waste equipment properly with accordance with local regulations and laws.

Specifications

Working Voltage

10.5~15V

Working Current

0.5~1.5A

Working Power

5~25W

Power Consumption

4w/seat

Storage Temp.

35.6~131°F

Working Temp.

35.6~122°F

One Year Limited Hardware Warranty

Your Viotek Seat Cushion ("Product") includes a One Year Limited Hardware Warranty ("Warranty"). The Warranty covers product defects in materials and workmanship under normal use. This Warranty is limited to residents of the United States and Canada only and is available only to original purchasers. This Warranty gives you specific legal rights and you may also have other rights which vary from state to state.

This Warranty starts on the date of your purchase and lasts for one year (the "**Warranty Period**"). The Warranty Period is not extended if the Product is repaired or replaced. We may change the availability of this limited warranty at our discretion, but any changes will not be retroactive.

Warranty services are provided by Warranty Pro ("WP"). If a hardware defect arises and a valid claim is received within the Warranty Period, at its option and to the extent permitted by law, WP will: (1) repair the hardware defect by using new or refurbished parts that are equivalent to new in performance and reliability; or (2) exchange the Product with a product that is new or refurbished which is substantially equivalent to the original product. This Warranty is for one replacement only of like-items and does not cover items out of production if the product is no longer made or stocked. This Warranty is not assignable or transferable. The original purchaser may call the toll-free number at 1-855-229-9472 for service requests.

When a product or part is exchanged, any replacement item becomes your property and the replaced item becomes WP's property. This warranty only covers technical hardware defectiveness during the warranty period and under normal use conditions. WP does not warrant uninterrupted or error-free operation of this Product.

This Warranty does not cover any damage due to: (a) transportation; (b) storage; (c) improper use; (d) failure to follow the product instructions or to perform any preventive maintenance; (e) modifications; (f) unauthorized repair; (g) normal wear and tear; or (h) external causes such as accidents, abuse, or other actions or events beyond our reasonable control.

Important: Do not disassemble the Product. Disassembling the Product will void this Warranty. Only WP or a party expressly authorized by WP should perform service on this Product.

DISCLAIMER OF WARRANTY: THE REMEDIES DESCRIBED ABOVE ARE YOUR SOLE AND EXCLUSIVE REMEDIES AND OUR ENTIRE LIABILITY FOR ANY BREACH OF THIS LIMITED WARRANTY. OUR LIABILITY SHALL UNDER NO CIRCUMSTANCES EXCEED THE ACTUAL AMOUNT PAID BY YOU FOR THE DEFECTIVE PRODUCT, NOR SHALL WE UNDER ANY CIRCUMSTANCES BE LIABLE FOR ANY CONSEQUENTIAL, INCIDENTAL, SPECIAL OR PUNITIVE DAMAGES OR LOSSES, WHETHER DIRECT OR INDIRECT.

SOME STATES DO NOT ALLOW THE EXCLUSION OR LIMITATION OF INCIDENTAL OR CONSEQUENTIAL DAMAGES, SO THE ABOVE LIMITATION OR EXCLUSION MAY NOT APPLY TO YOU.

THE DURATION AND REMEDIES OF ALL IMPLIED WARRANTIES, INCLUDING WITHOUT LIMITATION THE WARRANTIES OF MERCHANTABILITY AND FITNESS FOR A PARTICULAR PURPOSE ARE LIMITED TO THE DURATION OF THIS EXPRESS LIMITED WARRANTY.

VIOTEK